

WATER

# CP150i



## Diesel Drive Auto Prime Contractor Pump

The Contractors pump range has been designed to provide greater cost efficient fluid handling solutions for all users.

The range offers efficiency levels of 83% which translate into benefits for the end user and the environment.

Contractors pumps are a fully automatic priming pump and can run dry for extended periods due to the oil bath

mechanical seal assembly which allows priming with long suction hoses and suction lifts of up to 9 metres (28 feet). As fluid levels fluctuate, the pump will "snore" until the liquid is available for the pump to fully reprime itself automatically.

Built with the highest quality materials , 316 SS Impeller and wear plates as standard.

## CONTRACTORS RANGE

# 1800 PUMP RENTAL

[nationalpump.com.au](http://nationalpump.com.au) | [sales@nationalpump.com.au](mailto:sales@nationalpump.com.au)



# NPE

NATIONAL PUMP & ENERGY

## Features

- Low fuel usage
- Reduced engine sizes
- Lower maintenance costs
- Dry self prime and reprime
- Close coupled SAE Bearing Frames
- Suction lifts to 9m
- Operates in 'snore' conditions
- Vacuum Priming option available for ground dewatering.

- Diesel, electric or hydraulic drive
- Solids handling
- Simple maintenance
- Replaceable wear parts
- Chassis - skid, road tow, wheeled, caged
- Powered by Perkins or Cat Engines.
- Other engines available on request
- Custom build available
- Sykes purpose built Control panel

## Application

- Construction
- Environmental
- Industrial
- Mining
- Clean Water
- Sludge
- Slimes
- Sewage
- Solids laden liquids
- Ground Dewatering
- Pipeline & Drilling
- Jetting
- Quarries

## Technical Data

### MATERIALS OF CONSTRUCTION

Pump Casing:	S.G. IRON 400/12
Suction Cover:	S.G. IRON 400/12
Air Separation Tank:	S.G. IRON 400/12
Bearing Bracket:	S.G. IRON 400/12
Pump Shaft:	431 Stainless Steel
Impeller:	316 Stainless Steel
Wearplates:	316 Stainless Steel
Mechanical Seal:	Silicon Carbide/ Silicon Carbide
N.R.V. (Ball Type):	S.G. IRON 400/12

### DESIGN DETAILS

Single Stage, end suction type, 2 vane fully open impeller, Centrifugal pump  
 Suction Flange (mm/in): 150/6  
 Delivery Flange (mm/in): 150/6  
 Solids Handling Size (mm/in): 77/3  
 Maximum Head (m/ft): 60/197  
 Maximum Capacity: 172 L/sec

### FUEL USAGE (L/HR) @ BEP

Speed (rpm)	POWER USAGE (kW)	FUEL RATE (L/hr)	RUN TIME (hrs - 250L fuel tank)
1400	20	4.94	89
1800	38	9.39	47
2200	66	16.31	27

CALCULATIONS BASED ON 210 g/kw.hr

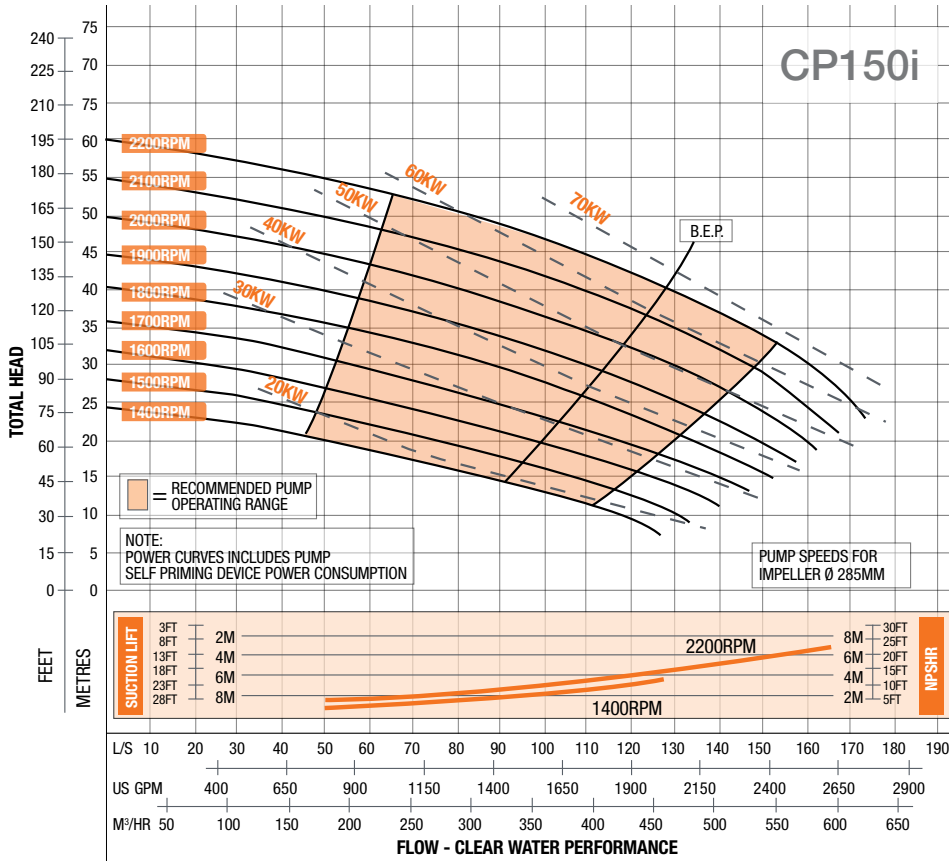

Dry Weight: 1510 kg  
 Fuel Capacity: 440 litres

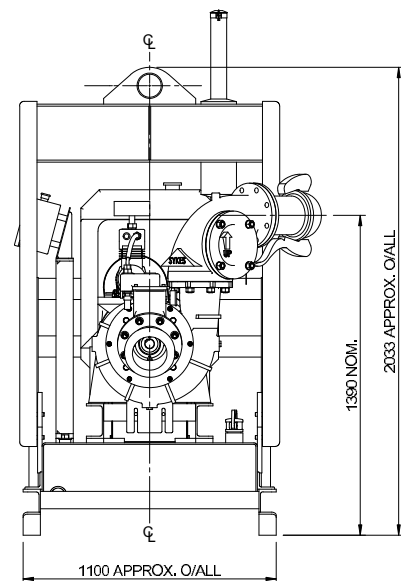
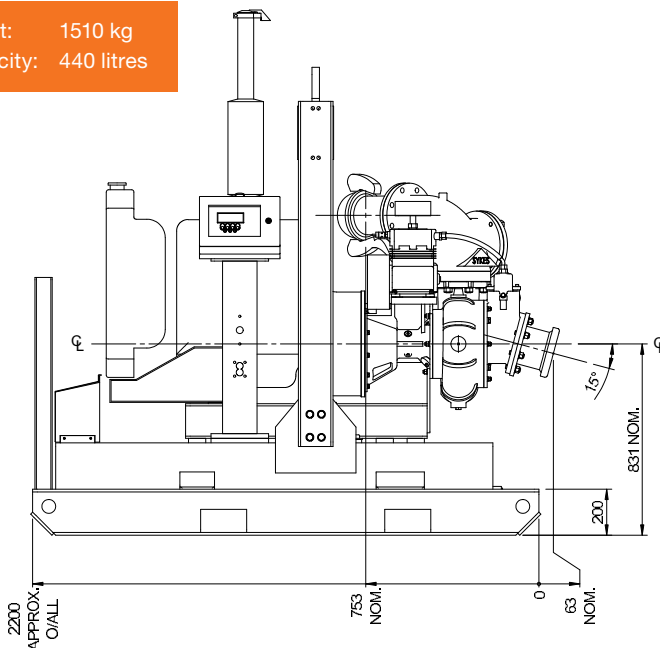

Final weight and dimensions will depend on completed specifications  
 All this information in this document is substantially correct at the time of printing and may be altered subsequently

NPE-MAR-SS-95

1800 PUMP RENTAL

nationalpump.com.au | sales@nationalpump.com.au



**NPE**  
 NATIONAL PUMP & ENERGY